

Product Overview

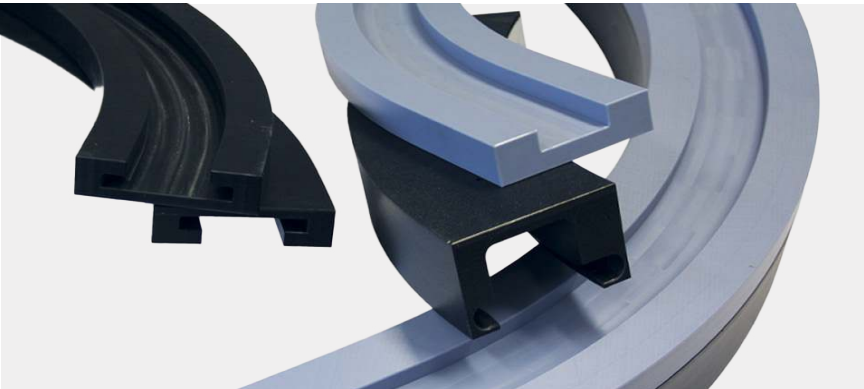

Movex
OFFICIAL UK PARTNER

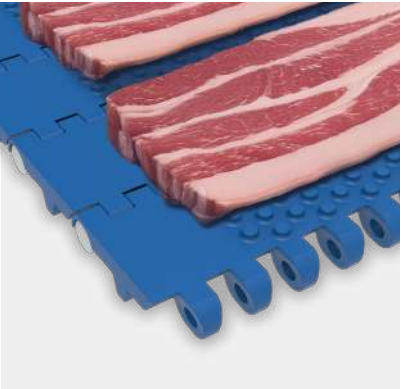
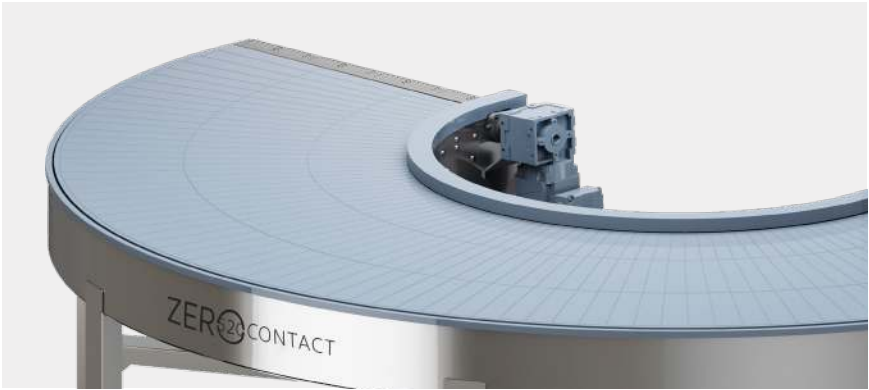

the people for conveyors

Oadby Plastics is the official UK distributor for Movex, bringing complete conveyor solutions to the UK food, beverage and packaging industries for over 40 years. Our specialist division, Oadby Conveyors, combines dedicated service with the backing of the UK's largest independent plastics stockholder and machinist, offering expert support and bespoke machining for conveyor systems.

Movex's innovative components are trusted globally and designed to reduce energy usage, minimise lubrication and improve product handling. Our core range includes belts, chains, sprockets, feet, brackets, clamps, guides, bearings and wear strips, which are available for next-day delivery alongside our belt assembly service to keep your lines moving.



The Complete Partnership



Customer Service Excellence



Bespoke Machined Conveyor Parts



Quality Assurance on Every Order



In-House Belt Assembly Service



Next Day Delivery on Core Stock



High Quality Products



Large Stockholding Facility



Movex **Blueline**

Movex® has expanded its expertise by developing a selection of products aimed at intercepting and meeting the needs of new sectors, such as the food, meat, poultry, seafood, bakery, vegetable, material handling, and automotive industries.

This new chapter in our company's history is called **Blueline**®.

[Explore our innovative solutions and experience the difference first-hand!](#)

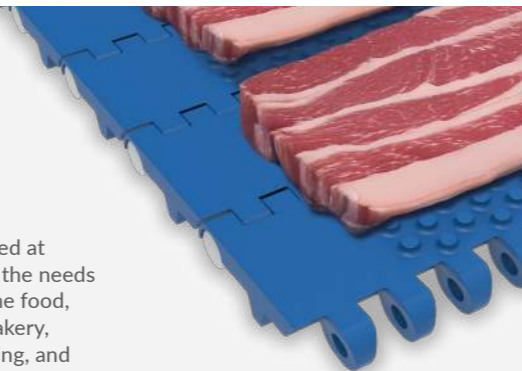

Contents

Modular Belts & Nose Bars	Page 4
Modular Solutions	Page 4
Zero Contact Curve Conveyor	Page 5
Steel Chains	Page 6
Plastics Chains	Page 6
Sprockets, Idler Wheels & Turning Disks	Page 6
Extruded Profiles	Page 7
Blueline® Hygienic Range	Page 8-11
Zero ATP Pro	Page 12
Conveyor Components	Page 13
Corner & Straight Tracks	Page 13
Return Components	Page 14
Conveyor Support Components	Page 14
Bearing Supports	Page 14
Leveling Feet	Page 14
Belt Assembly Service	Page 15
533 Sorter ⁺	Page 16
533 Flex Top	Page 17
Machining Capabilities	Page 18

MODULAR BELTS & NOSEBARS

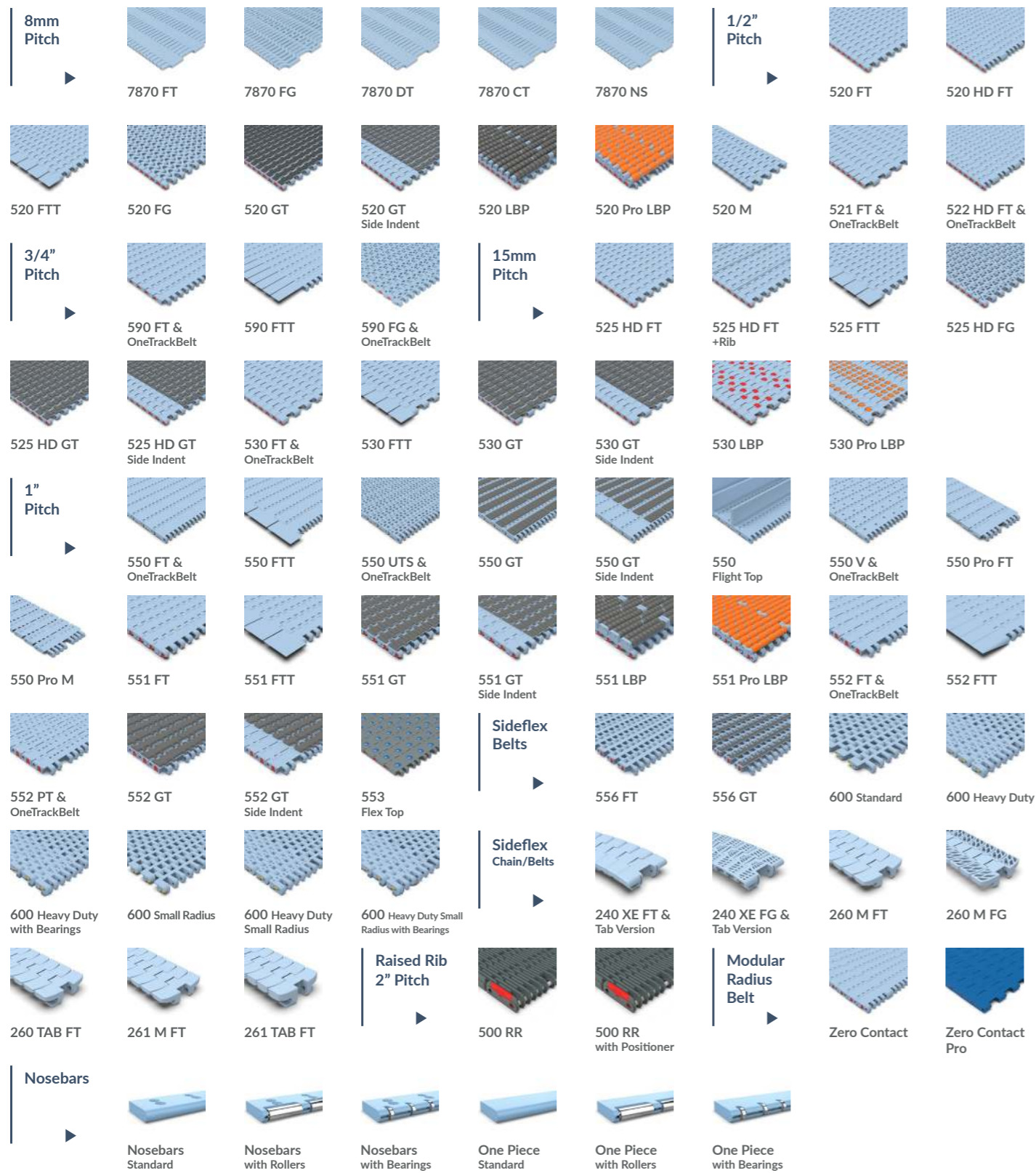

MODULAR SOLUTIONS



ZER⁵²⁰CONTACT

CURVE CONVEYOR



Product Use

Zero Contact™ curve conveyor is available in different widths with a closed-top surface capable of handling a variety of packaging sizes, types and configurations, including delicate products and applications found on shrink wrappers.

Zero Contact™ is designed to be used for the transport of various sized parts, is suitable for the food and beverage industry, thanks to FDA approval, and helps reduce energy consumption, improving the line efficiency. It can be easily connected to the existing layout.



INNER RADIUS: 600mm - 2000mm

BELT WIDTH: 200mm - 1600mm

MATERIAL OF MODULES: Acetal (POM)

COLOUR OF MODULES: Pigeon Blue (RAL 5014)

PINS PBT: White

PIN LOCK: Clips

FRAME: Stainless Steel

TEMPERATURE RANGE

Dry: -40°C - 80°C | Wet: -40°C - 65°C

(Dry: -40°F - 176°F | Wet: -40°F - 149°F)

MAX. WORKING LOAD

13.500 N/m belt width

CURVE ANGLE: 15° - 360°

OPEN AREA: 0%

STEEL CHAINS

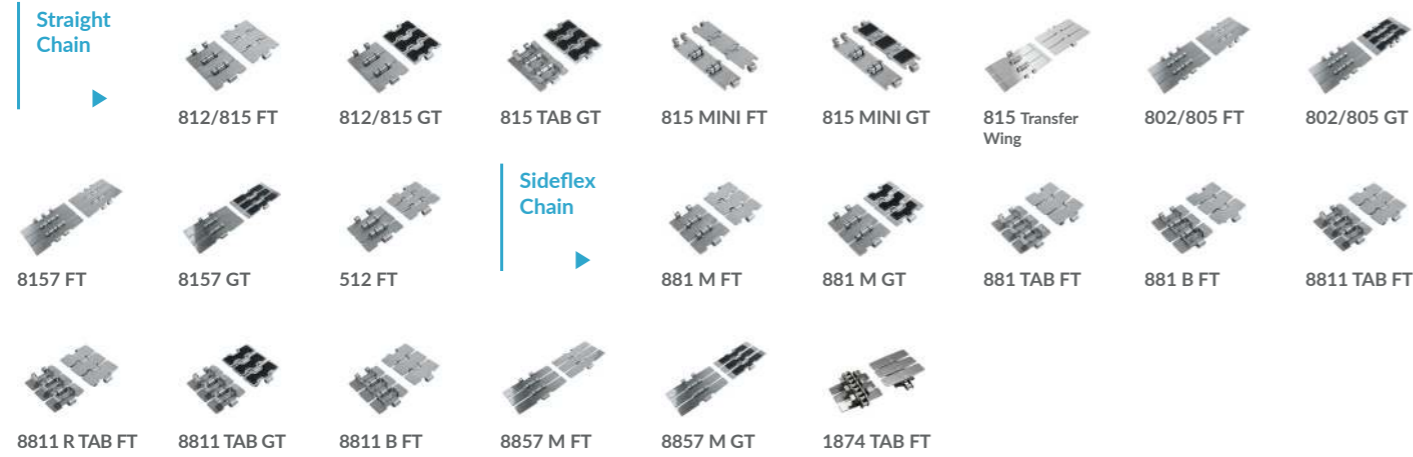

PLASTIC CHAINS

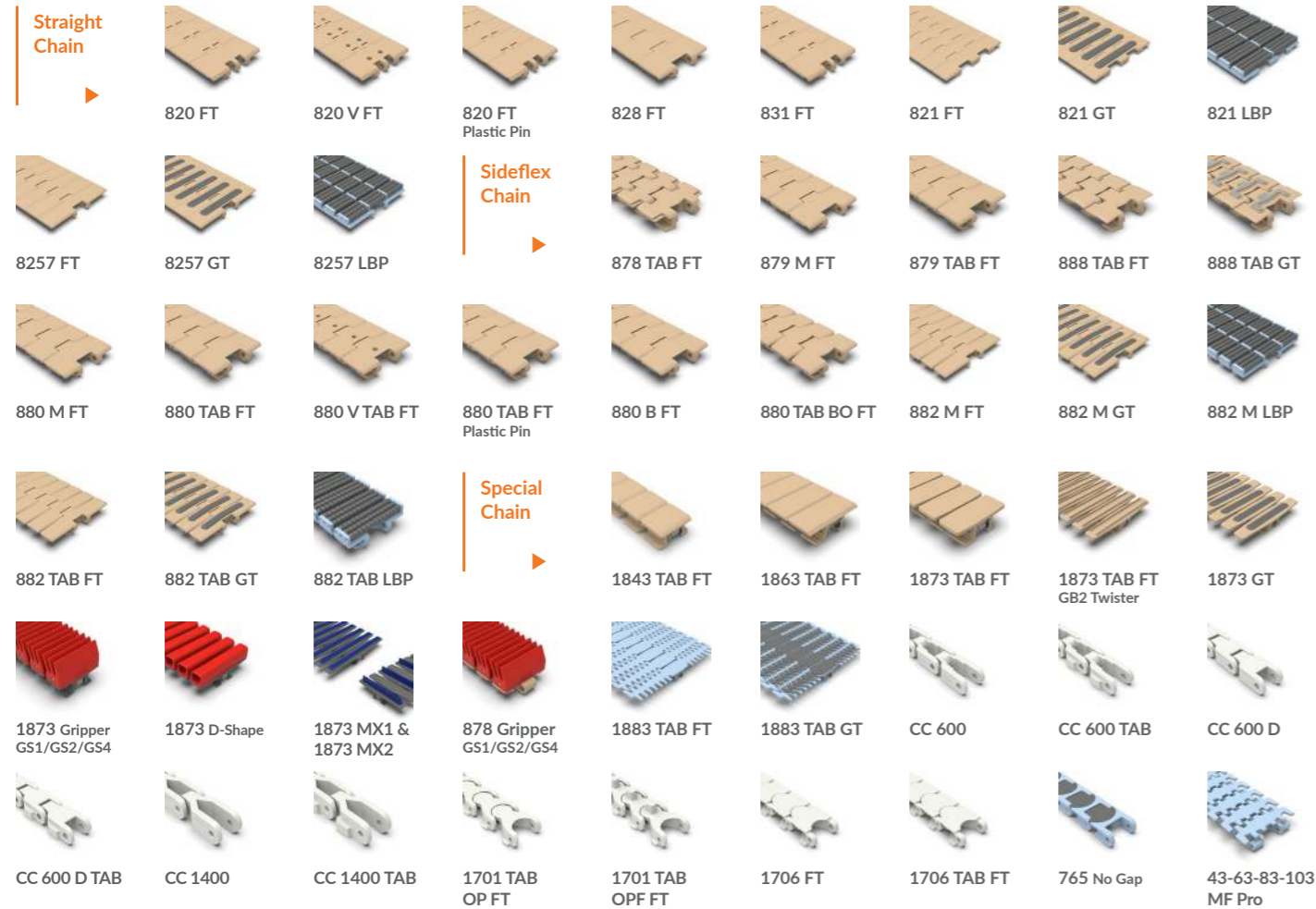

SPROCKETS, IDLER WHEELS & TURNING DISKS



Movex provides many different types of sprockets and idler wheels, machined or moulded, split or solid, ideal to cover all application needs. Specifically designed for side flexing chains, Movex also provides machined and moulded turning disks.

EXTRUDED PROFILES

Available in **BluLub** / **Ti-White** / **UHMW-PE**

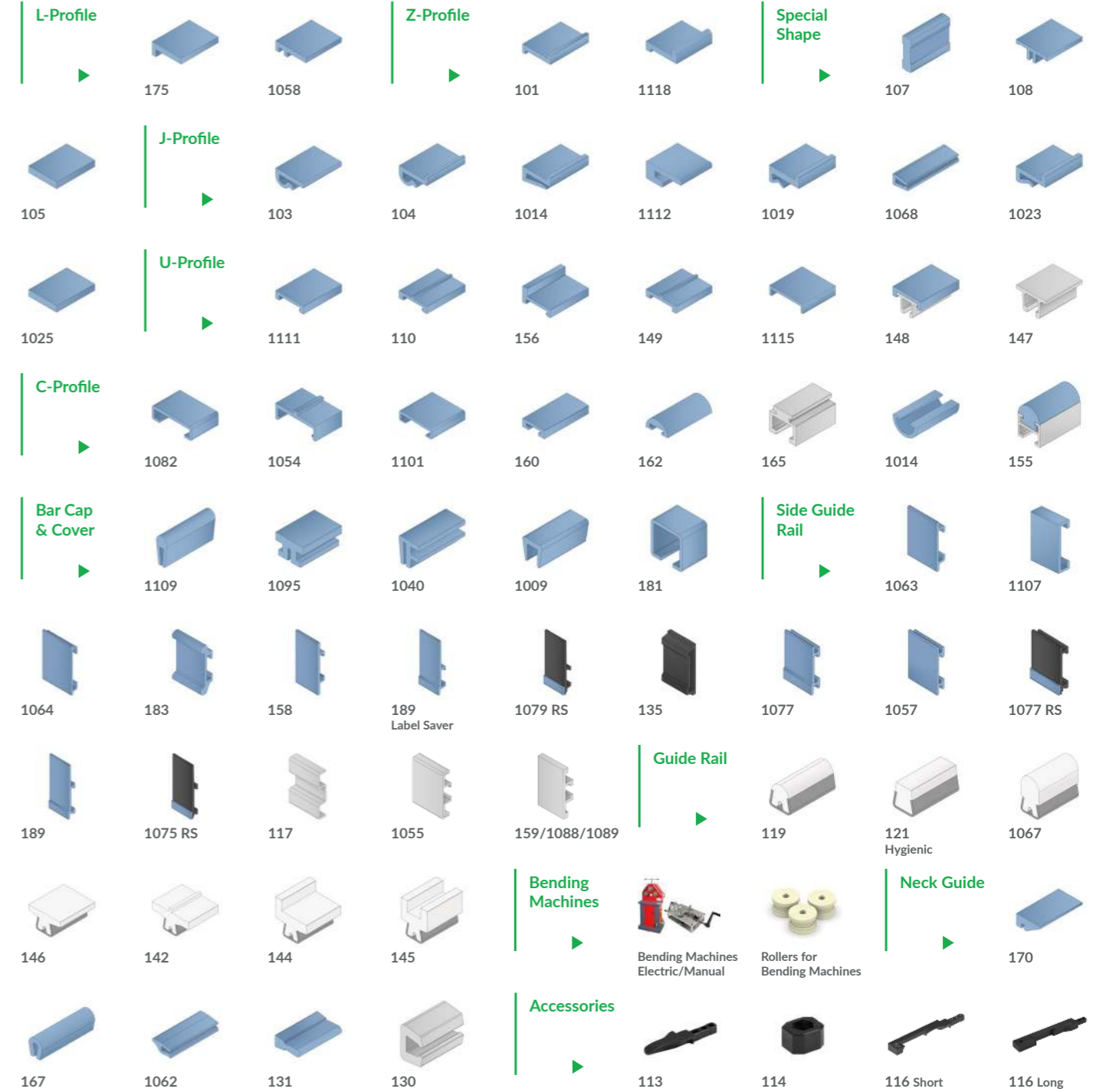

This is a smaller selection of the extruded profiles we have available, find the complete range in our general catalog.

BluLub® & PFX Your powerful dry running combination

BluLub is Movex's performance compounded Ultra High Molecular Weight Polyethylene material, with the latest generation of solid lubricants. It is ideal for producing a large range of sliding parts (extruded profiles, machined curves, nosebars).

PFX is the plastic compound developed for chains and belts to run with limited lubrication and/or in dry applications where the demands are extreme, concerning speed, performance and efficiency.

The combination of **BluLub** and **PFX** is the perfect choice to achieve a sustainable dry running line, saving water, energy and cost, minimising power consumption and improving environmental safety, as well as hygienic aspects.



Movex Blueline®

Movex
Blueline®

in partnership with



Movex has developed an exceptional series of modular belts tailored precisely to your sector's specific needs.

With a wide variety of surface types, including flat top, flush grid, cone top, nub top, perforated top, non-slip, and diamond-top, our belts ensure optimal performance for your specific applications. But that's not all.

Our extensive range of accessories, from non-stick and flat flights to straight and curved tracks, along with sidewalls, guarantees seamless integration and enhanced functionality. We guarantee complete interchangeability with major food belt producers, providing you with unparalleled versatility and flexibility. Plus, our specialty lies in crafting custom products tailored to your unique needs, with the added advantage of short lead times.

Explore our innovative solutions and experience the difference first-hand!

MODULAR BELTS

8mm Pitch						12.7mm Pitch			
							19.05mm Pitch		
Modular Radius Belt						50.8mm Pitch			
							<p>Accessories Available for selected belts</p>		

MODULAR SOLUTIONS

Zero Contact	Zero Contact S	Zero Contact Flat Edge	Zero Contact Hygienic	Zero Contact Pro	Zero Contact Pro - 2 Tracks
Zero ATP	Zero ATP Pro	553 Sorter*			

Increase your productivity with modular solutions' plug-and-play units, designed for seamless integration. Made entirely with our high-quality components, ensuring durability, reliability and top performance.

Available in various sizes and configurations, these solutions can be easily connected to your existing layout, optimising workflow with minimal downtime.

Find the best solution for your application.

Visit our website to explore the possible configurations or contact your sales representative directly.
www.oadbyconveyors.co.uk

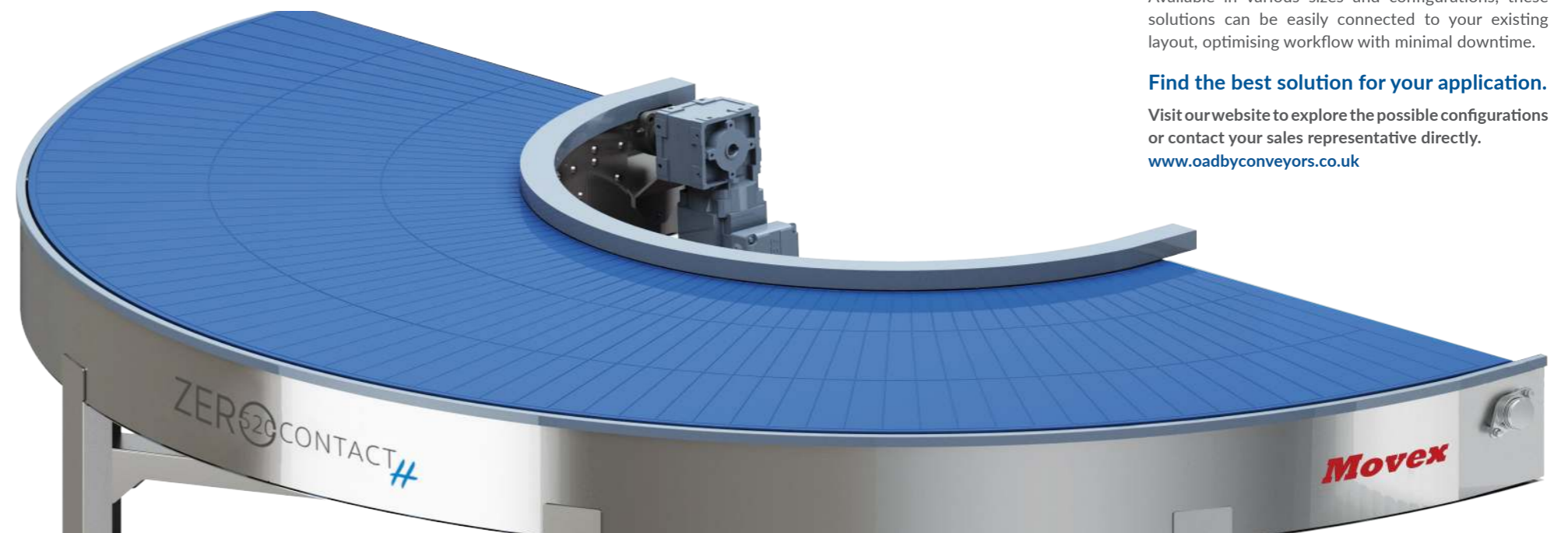

SPROCKETS



EXTRUDED PROFILES

Available in **BluLub®** / **Ti-White®** / **UHMW-PE** / **AS Antistatic**

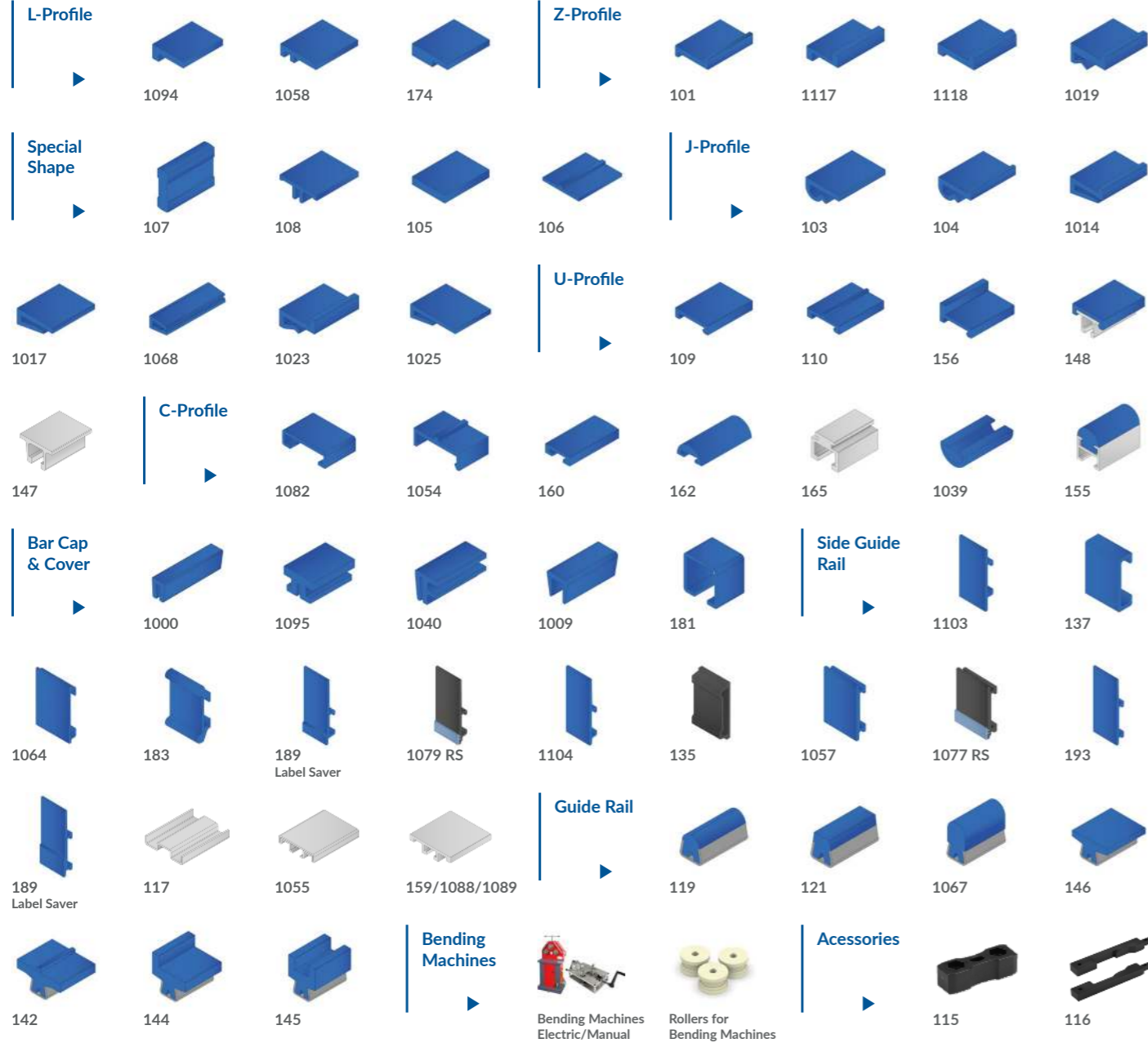

RETURN COMPONENTS



CONVEYOR COMPONENTS



CONVEYOR SUPPORT COMPONENTS



BEARING SUPPORTS



LEVELING FEET



ZEROPRO ATP[®]

ACTIVE TRANSFER PLATE



100%
GUARANTEED
TRANSFER!

DIFFERENT BELT SURFACE AVAILABLE ON REQUEST

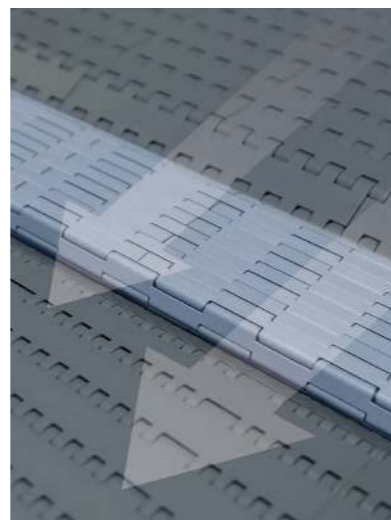

Product Use

Zero ATP™ Pro equipped with micro-pitch 510 modular belt series, is the smallest Active Transfer Plate available on the market.

With its revolutionary compact shape, Zero ATP™ Pro is the right choice to connect different conveyors, guaranteeing a smooth product transfer, that can be easily integrated into existing lines by replacing traditional transfers, with limited structural work.

Zero ATP™ Pro can be provided with a mini-motor or key shaft for a roller chain drive, and is a maintenance and tensioning-free system.

CONVEYOR COMPONENTS

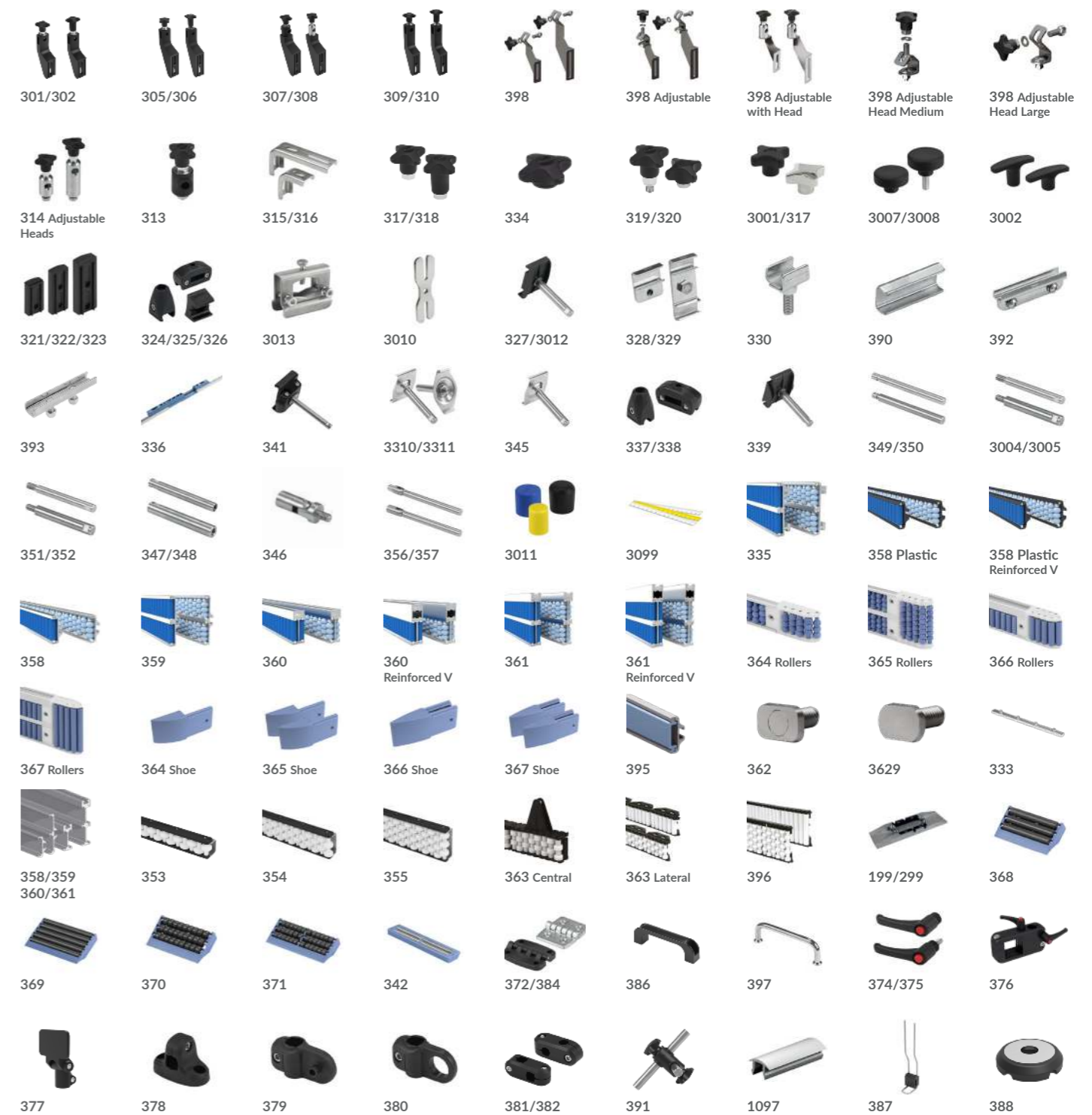

CORNER & STRAIGHT TRACKS - MAGNETIC, TAB & BEVEL

Designed to offer better conveyor performance, Movex corner tracks are produced with computer-controlled machines and a smooth chain guide surface. They are suitable for chains and modular belts in different materials and designs:



Available in **BluLub** / **C Abrasive** / **UHMW-PE** / **RS**. Curves

Various curve materials are available to ensure compatibility with the application conditions.

BELT SERIES: 510 FT

BELT WIDTH: 6in - 24in (152.4mm - 609.6mm)

MATERIAL DIMENSIONS: Pitch 8mm | Thickness 6mm

MATERIAL OF MODULES: LFA, MX and LFB

TRANSFER LENGTH: 90mm or 150mm

TRANSMISSION: Mini-motor or Keyed shaft

MAX. WORKING LOAD: 3.000 N/m belt width

SIMULTANEOUS TRANSPORT OF:

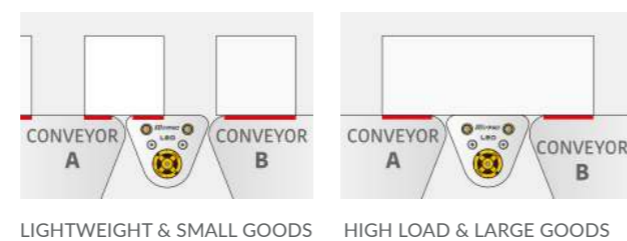

Plug-in & Play solution | Maintenance-free | Self-tensioning

RETURN COMPONENTS



CONVEYOR SUPPORT COMPONENTS



BEARING SUPPORTS



LEVELLING FEET



In-House Modular Belt Assembly

Reduce costly downtime and avoid delays with our in-house modular belt assembly service designed to fit most conveyor solutions. With fast, precise assembly and next-day shipping options for the food, beverage and packaging industries, Oadby Conveyors is committed to keeping your production lines moving at all times. Our tailored support helps ensure maximum efficiency and reliable performance in demanding applications.

Movex
BlueLine[®] assembly also available

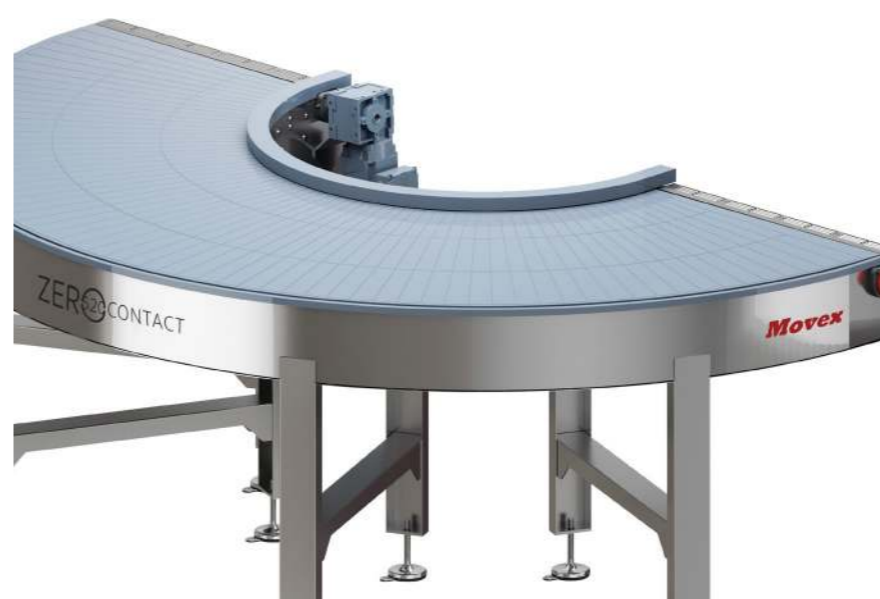
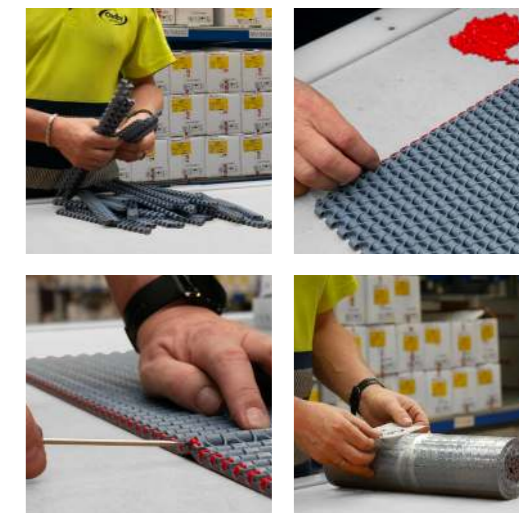

Priority Service
Dispatched within 24 hours

Associated sprockets available from stock ✓



Contact our expert sales team to find out more:
0116 232 4848 | convteam@oadbyplastics.co.uk

553 SORTER+

MULTIDIRECTIONAL CONVEYOR

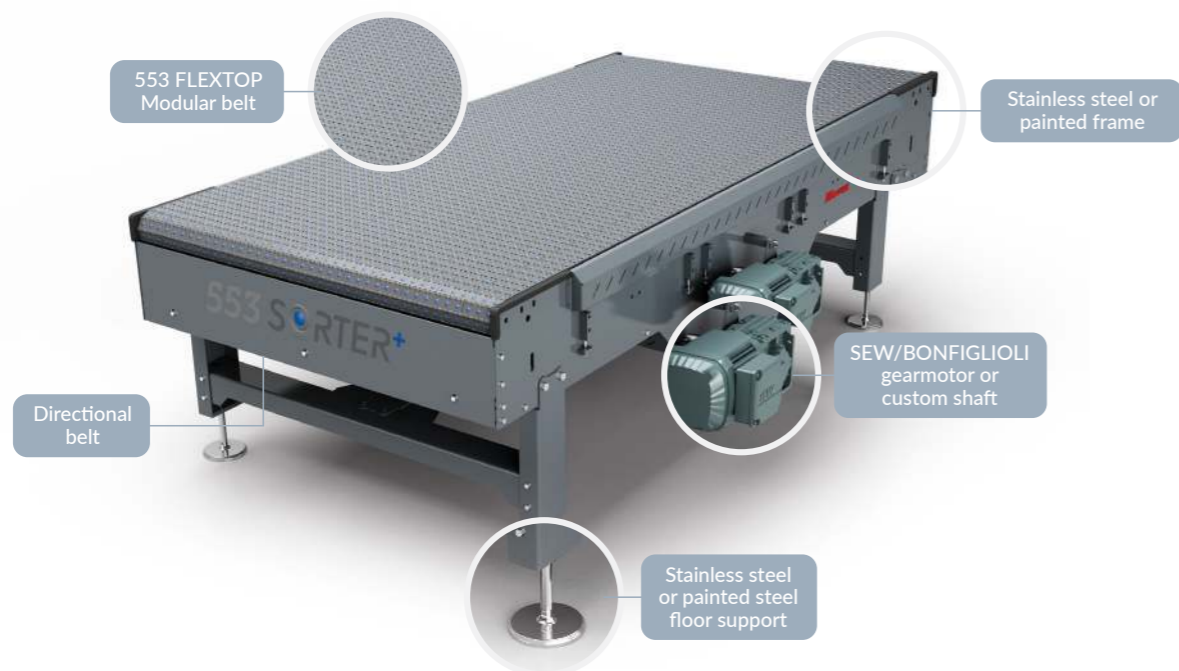

Product Use

553 Sorter Plus™ is a multidirectional conveyor, equipped with the unique and patented 553 FlexTop modular belt, and with a directional belt or plate, is the ideal solution to transport countless types of products and for several types of industries. It can be easily integrated into existing systems

The 553 Sorter Plus™ is available in different widths and lengths in four different versions:

- **Diverter** - able to quickly move your goods side to side
- **Static Turn** - able to rotate your goods statically

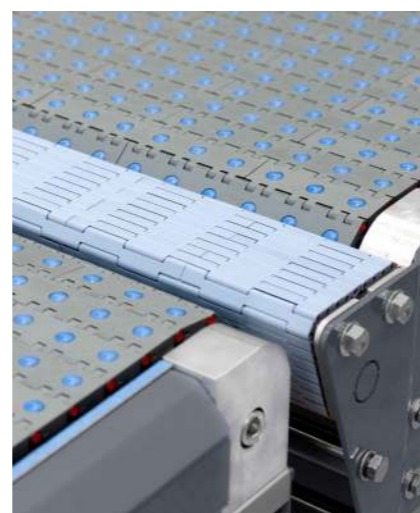

BELT PITCH: 25.4mm
THICKNESS: 8.7mm
INCREMENTS: 76.2mm
TOTAL LENGTH: 600mm - 1400mm
TOTAL WIDTH: 390mm - 1000mm
MATERIAL OF MODULES: Dark grey Acetal (POM)
MATERIAL OF SPHERES: Blue Polyamide (PA)

TEMPERATURE RANGE
 Dry: -40°C - 80°C | Wet: N/A
 (Dry: -40°F - 176°F | Wet: N/A)
MAX. WORKING LOAD
 27.500 N/m belt width
OPEN AREA: 0%
FRAME: Stainless steel or Painted steel

553 FLEX TOP

Backflex radius min.: 25mm

The new Movex 553 FlexTop modular belt with self-locking spheres is specifically designed for high-precision material handling, suitable for several applications like logistic centres, packaging stations (food and beverage) and corrugated industries, as it is easily integrated into existing systems. The 360° movement possibility makes the belt suitable for diverting, rotation, accumulation and acceleration applications and minimises required maintenance and downtime. The small pitch between the spheres allows every type of product transfer and is ideal for small and light packages, unlike traditional roller conveyors.

The complete closed sliding belt surface is the perfect solution to carry carton boxes, crates, shrink-wrap packaging for cans and bottles and any kind of polybag with top-accuracy package control. **553 FlexTop is the best choice for material handling applications!**

High Strength

Design and features of 553 FlexTop make it ideal for the transport of several type of products (e.g. polybags, shrink-wrap packaging).

Perfect Product Control

The small pitch between the spheres allows for great product-control.

Self Cleaning

A complete closed sliding surface, in combination with self-locking spheres, makes the belt design flexible and robust.

Great Versatility

The directional belt underneath the flextop belt controls the direction and the speed of the spheres, making this belt 100% versatile.

Long Durability

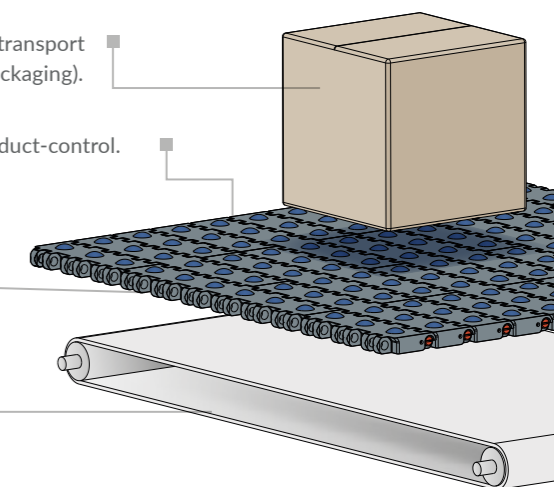

DIVERTING

Side movement

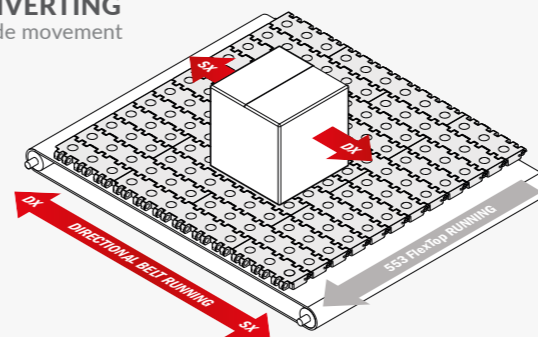

By using a directional belt underneath the Flextop belt, running square to the travel direction, the product can be transferred left and right.

ROTATION

Product Stopped

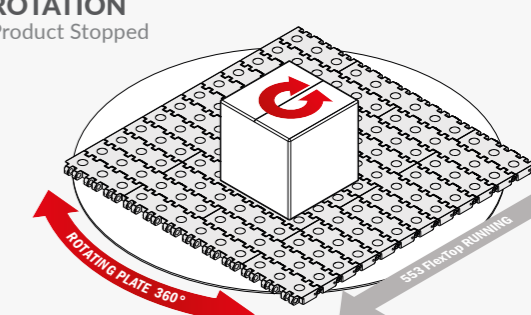

By using a rotating plate underneath the Flextop belt, the sphere can rotate by 360°. This option can be used with product stopped or running on the belt to easily position the product.

DYNAMIC ROTATION

Product moving

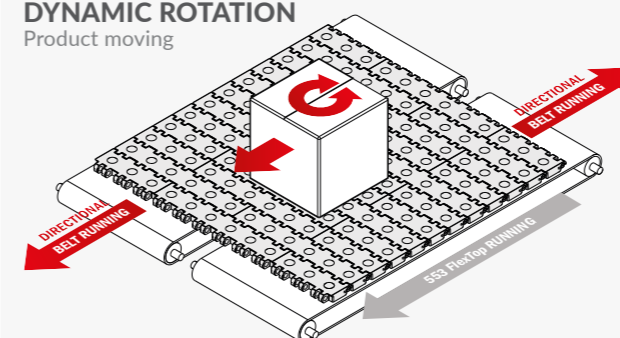

By using two auxiliary belts, running in opposite directions underneath the Flextop belt, the product will start rotating. With this option, the Flextop belt can keep running.

ACCELERATION

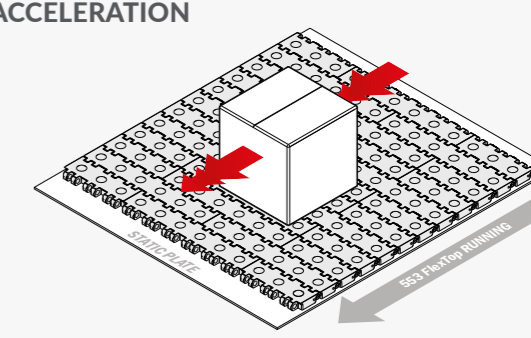

By using a static plate underneath the Flextop belt, the spheres will start rotating independently, so the speed of the product will be double the speed of the belt itself.

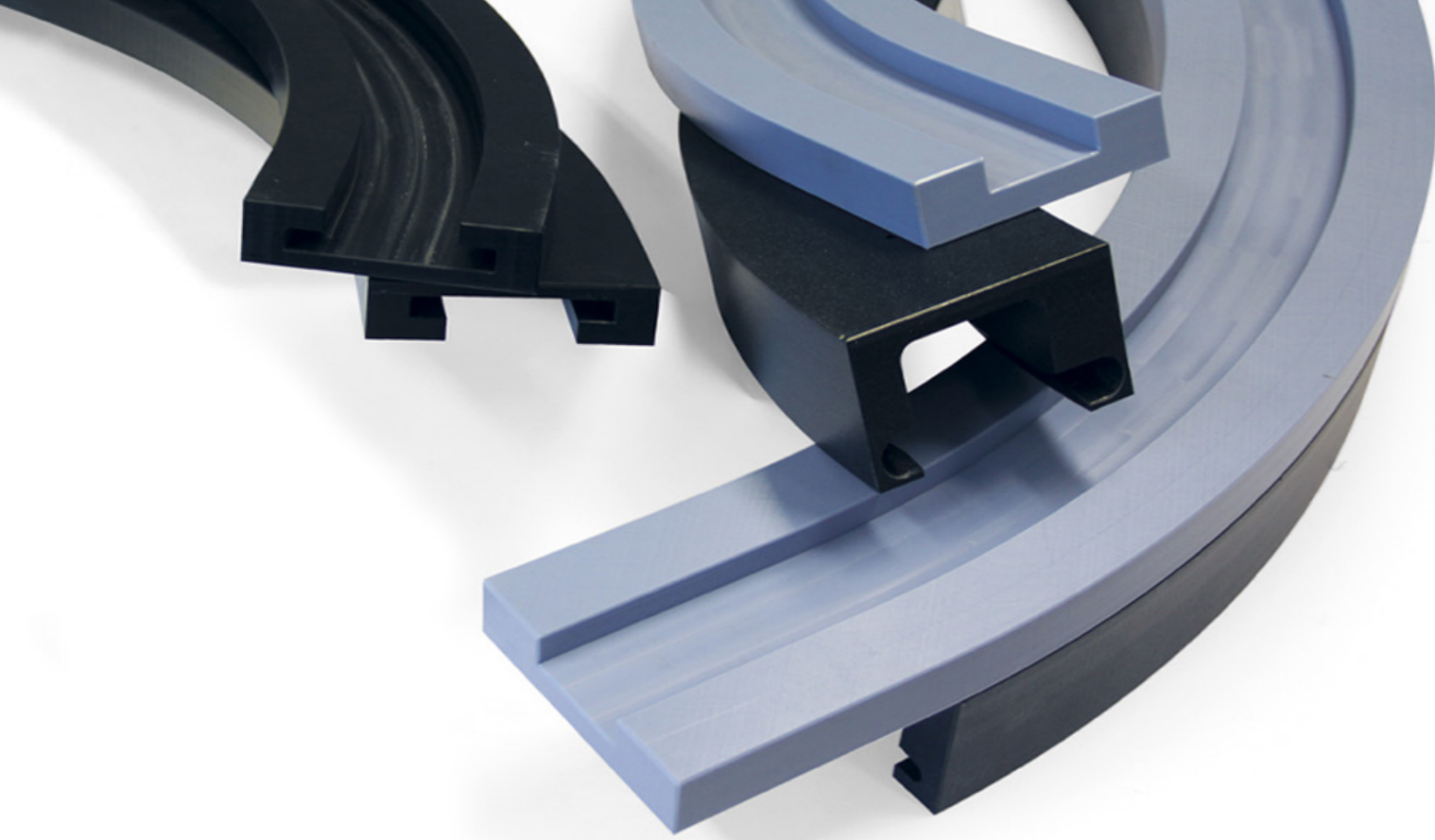

Movex®

To forge our values through the development of ideas and high standards, and to professionally support our partners with flexibility and efficiency.



Machining Capabilities at Oadby

We have over 225,000 sq. ft. dedicated to precision machining and distribution. Our 3 and 5-axis CNC technology supports complex, high-accuracy projects, while our other specialist areas facilitate fabricated assemblies and custom components, ideal for guide rails and guarding. Quality assurance checks also ensure all parts meet exact specifications.



CNC Machining

High-precision 3-axis and 5-axis routing handles complex geometries and tight tolerances with exceptional accuracy, meeting complex specifications and machining guide rails with ease.



Manual Machining

Our custom profiling keeps your systems running smoothly, with accurately shaped wear strips for your exact conveyor models reducing friction, improving performance and extending equipment life.



Fabrication

We can design and fabricate custom solutions like conveyor guarding, using durable materials like polycarbonate and PETG to enhance safety, visibility and reliability on your conveyor production line.



Technical Services

Our dedicated technical team performs thorough quality assurance checks with industry-leading technology and 3D scanners to ensure every part meets the exact specifications of your project.

Employees worldwide

350

Products available

35,000

Satisfied customers

2,000

Products delivered (daily)

98,000



Committed to delivering tailored conveyor solutions backed by precision machining, expert support and belt-assembly services to help customers improve operational efficiency.



Movex
OFFICIAL UK PARTNER

Oadby Conveyors

Oadby Conveyors
68 Scudamore Road
Braunstone Frith Ind. Est.
Leicester
LE3 1UA

0116 232 4848
convteam@oadbyplastics.co.uk

Head Office

Oadby Plastics Ltd
68 Scudamore Road
Braunstone Frith Ind. Est.
Leicester
LE3 1UA

0116 232 1010
sales@oadbyplastics.co.uk

For further information and specification details please visit our comprehensive website. Due to a policy of continual product development, Oadby Conveyors reserves the right to alter any of the specifications given in the publication without prior notice. The specification must be checked with Oadby Conveyors prior to manufacture. For this reason no responsibility or liability for accuracy is accepted by Oadby Conveyors.

Company registration No. 03542957 | www.oadbyconveyors.co.uk



Certificate Number 8147
ISO 9001, ISO 14001