

Product Overview

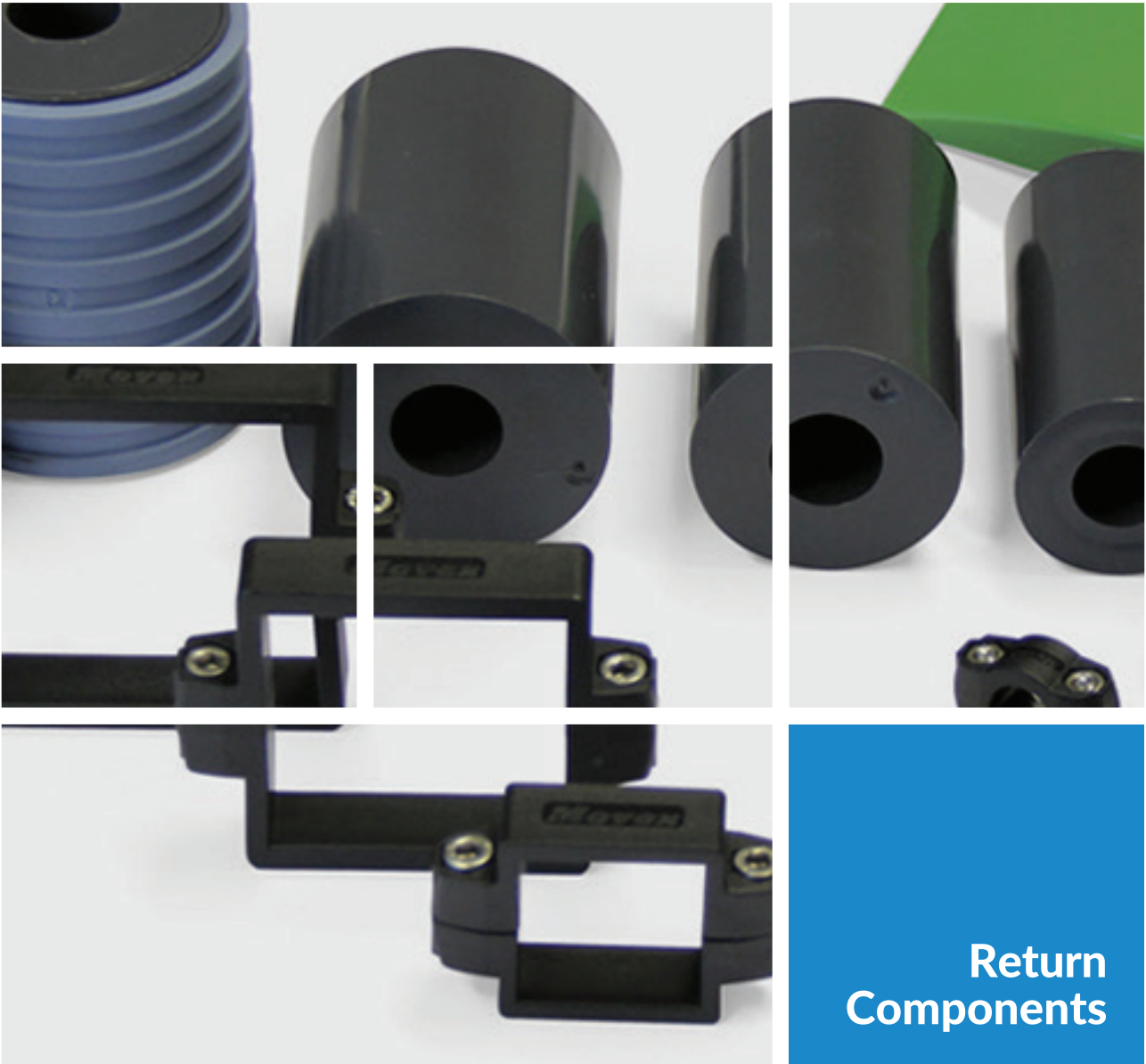

Return
Components



Movex[®]
OFFICIAL UK PARTNER

497

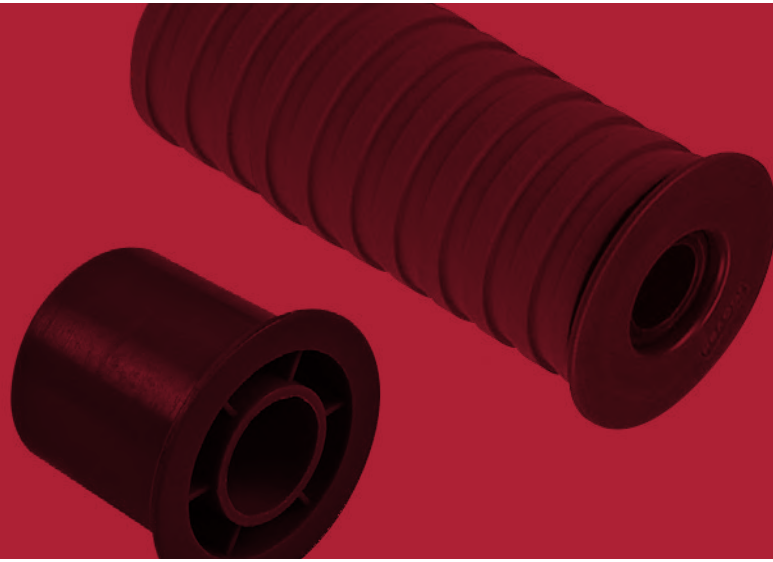

Return components



219 Rullini di ritorno D=40 mm Return roller D=40 mm / Rückführrolle D=40 mm

WATERTIGHT

Delivery: **Easy** **Standard**



Part	Article-Nr.	L	ØA
219	21951	41	16
219	21952	41	18
219	21953	41	20
219	21901	82,5	16
219	21902	82,5	18
219	21903	82,5	20
219	21911	84,5	16
219	21912	84,5	18
219	21913	84,5	20
219	21964	116	12
219	21961	116	16
219	21962	116	18
219	21963	116	20

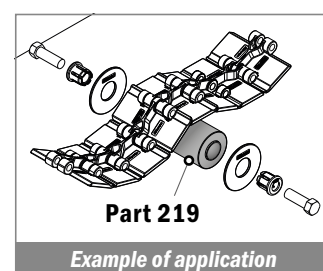
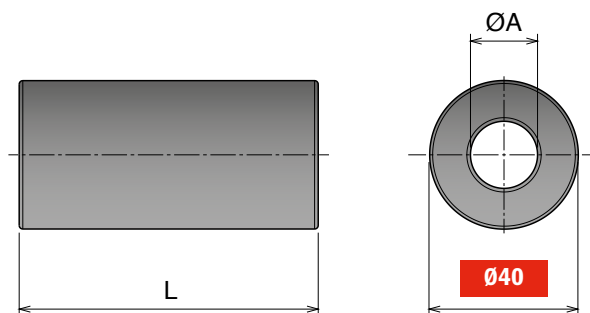

220 Rullini di ritorno gommati D=47 mm Return roller with rubber D=47 mm / Rückführrolle gummiert D=47 mm

WATERTIGHT

Delivery: **Easy** **Standard**



Part	Article-Nr.	L	ØA
220	22051	41	16
220	22052	41	18
220	22053	41	20
220	22001	82,5	16
220	22002	82,5	18
220	22003	82,5	20
220	22011	84,5	16
220	22012	84,5	18
220	22013	84,5	20
220	22064	116	12
220	22061	116	16
220	22062	116	18
220	22063	116	20

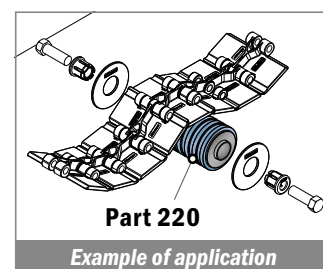
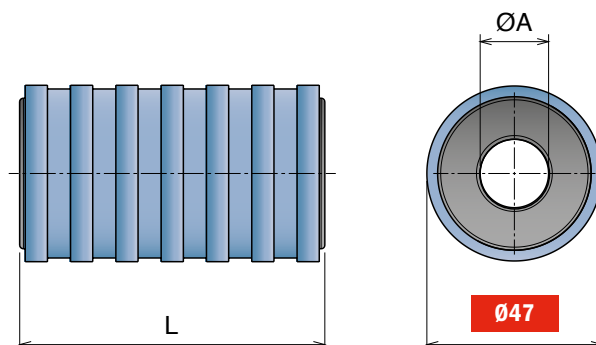

Materiale / Material / Materialien:
 Rullino: Polietilene (PE)/Roller: Polyethylene (PE)
 Rückführrolle Polyäthylen (PE)
 Gomma: TPR / Rubber: TPR / Gummi: TPR

201 Rullini di ritorno D=50 mm Return roller D=50 mm / Rückführrolle D=50 mm

WATERTIGHT

Delivery: **Easy** **Standard**

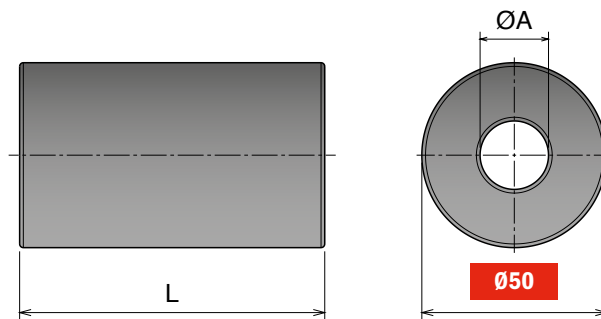

Part	Article-Nr.	L	ØA
201	20151	41	16
201	20152	41	18
201	20153	41	20
201	20101	82,5	16
201	20102	82,5	18
201	20103	82,5	20
201	20111	84,5	16
201	20112	84,5	18
201	20113	84,5	20
201	20164	116	12
201	20161	116	16
201	20162	116	18
201	20163	116	20

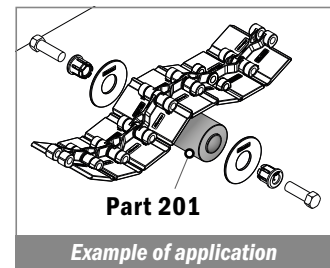

203 Rullini di ritorno gommati D=57 mm Return roller with rubber D=57 mm / Rückführrolle gummiert D=57 mm

WATERTIGHT

Delivery: **Easy** **Standard**

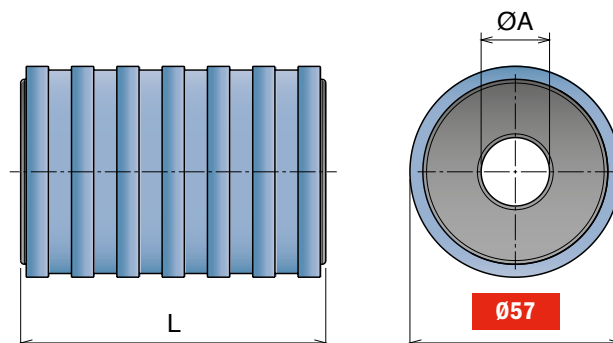

Part	Article-Nr.	L	ØA
203	20351	41	16
203	20352	41	18
203	20353	41	20
203	20301	82,5	16
203	20302	82,5	18
203	20303	82,5	20
203	20311	84,5	16
203	20312	84,5	18
203	20313	84,5	20
203	20364	116	12
203	20361	116	16
203	20362	116	18
203	20363	116	20

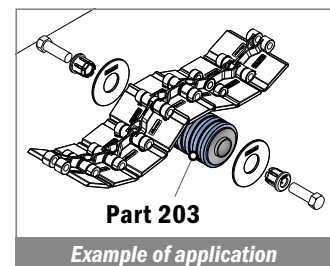

202 Rullini di ritorno D=60 mm Return roller D=60 mm / Rückführrolle D=60 mm

WATERTIGHT

Delivery: **Easy** **Standard**



Part	Article-Nr.	L	ØA
202	20251	41	16
202	20252	41	18
202	20253	41	20
202	20201	82,5	16
202	20202	82,5	18
202	20203	82,5	20
202	20211	84,5	16
202	20212	84,5	18
202	20213	84,5	20
202	20264	116	12
202	20261	116	16
202	20262	116	18
202	20263	116	20

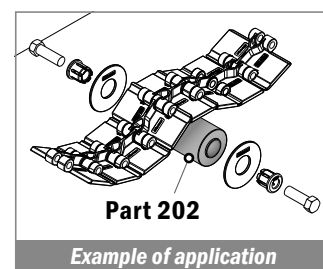
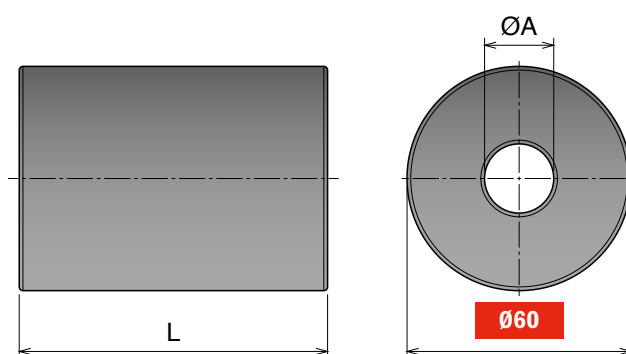

204 Rullini di ritorno gommati D=67 mm Return roller with rubber D=67 mm / Rückführrolle gummiert D=67 mm

WATERTIGHT

Delivery: **Easy** **Standard**



Part	Article-Nr.	L	ØA
204	20451	41	16
204	20452	41	18
204	20453	41	20
204	20401	82,5	16
204	20402	82,5	18
204	20403	82,5	20
204	20411	84,5	16
204	20412	84,5	18
204	20413	84,5	20
204	20464	116	12
204	20461	116	16
204	20462	116	18
204	20463	116	20

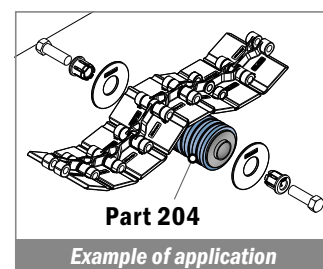
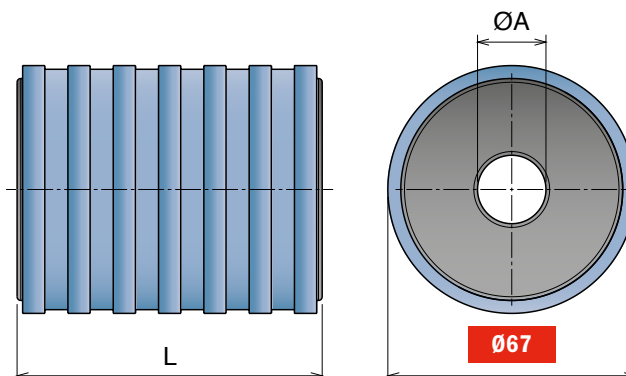

Materiale / Material / Materialien:
 Rullino: Polietilene (PE)/Roller: Polyethylene (PE)
 Rückführrolle Polyäthylen (PE)
 Gomma: TPR / Rubber: TPR / Gummi: TPR

222 Rullini di ritorno flangiati D=40 mm Return roller with flange D=40 mm / Rückführrolle mit Seitenscheibe D=40 mm

WATERTIGHT

Delivery: **Easy** **Standard**

Part	Article-Nr.	L	ØA
222	22251	43	16
222	22252	43	18
222	22253	43	20
222	22201	85,5	16
222	22202	85,5	18
222	22203	85,5	20
222	22211	87,5	16
222	22212	87,5	18
222	22213	87,5	20
222	22264	119	12
222	22261	119	16
222	22262	119	18
222	22263	119	20

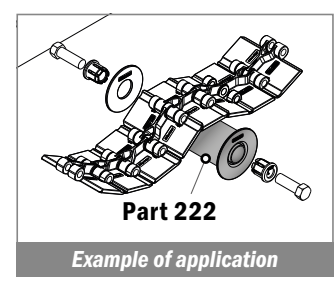
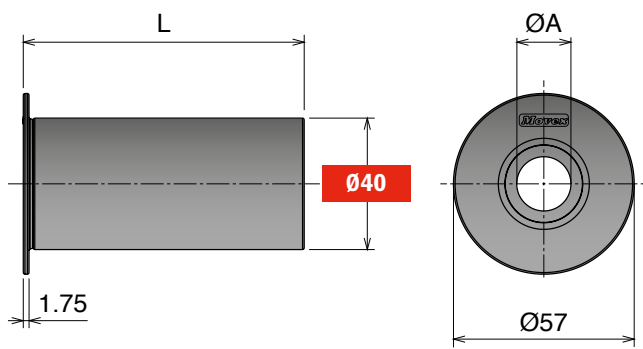

223 Rullini di ritorno flangiati gommati D=47 mm Return roller with flange and rubber D=47 mm / Rückführrolle gummiert mit Seitenscheibe D=47 mm

WATERTIGHT

Delivery: **Easy** **Standard**

Part	Article-Nr.	L	ØA
223	22351	43	16
223	22352	43	18
223	22353	43	20
223	22301	85,5	16
223	22302	85,5	18
223	22303	85,5	20
223	22311	87,5	16
223	22312	87,5	18
223	22313	87,5	20
223	22364	119	12
223	22361	119	16
223	22362	119	18
223	22363	119	20

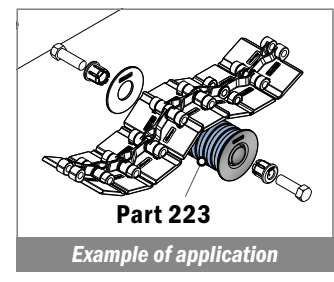
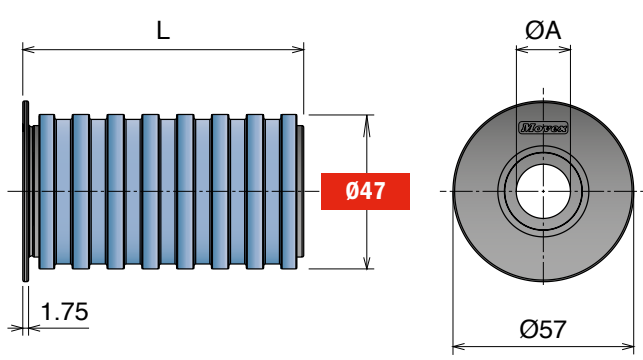

224 Rullini di ritorno flangiati D=50 mm Return roller with flange D=50 mm / Rückführrolle mit Seitenscheibe D=50 mm



Delivery: **Easy** **Standard**



Part	Article-Nr.	L	ØA
224	22451	43	16
224	22452	43	18
224	22453	43	20
224	22401	85,5	16
224	22402	85,5	18
224	22403	85,5	20
224	22411	87,5	16
224	22412	87,5	18
224	22413	87,5	20
224	22464	119	12
224	22461	119	16
224	22462	119	18
224	22463	119	20

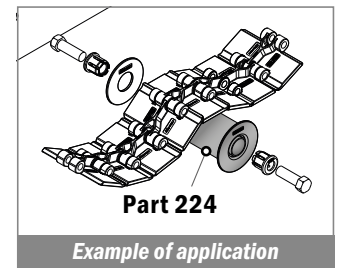
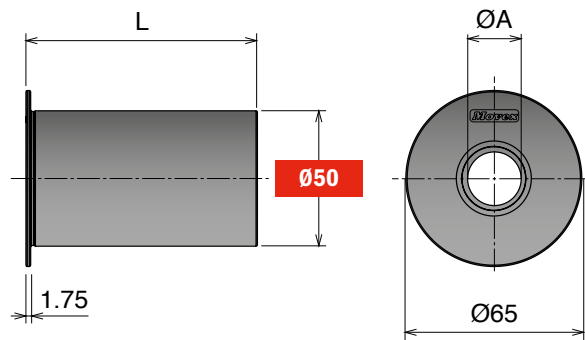

225 Rullini di ritorno flangiati gommati D=57 mm Return roller with flange and rubber D=57 mm / Rückführrolle gummiert mit Seitenscheibe D=57 mm



Delivery: **Easy** **Standard**



Part	Article-Nr.	L	ØA
225	22551	43	16
225	22552	43	18
225	22553	43	20
225	22501	85,5	16
225	22502	85,5	18
225	22503	85,5	20
225	22511	87,5	16
225	22512	87,5	18
225	22513	87,5	20
225	22564	119	12
225	22561	119	16
225	22562	119	18
225	22563	119	20

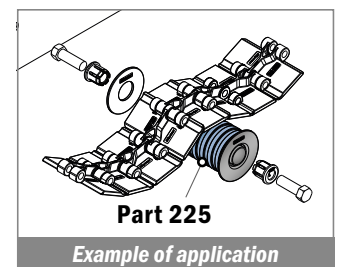
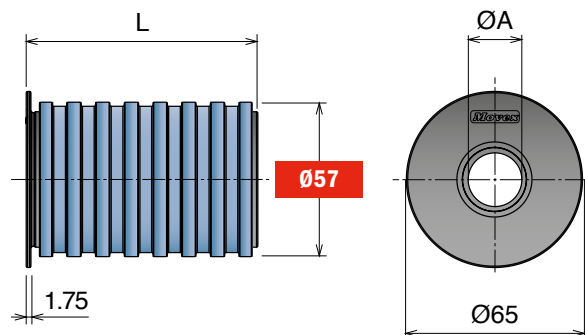

Materiale / Material / Materialien:

Rullino: Polietilene (PE)/Roller: Polyethylene (PE)
 Rückführrolle Polyäthylen (PE)
 Gomma: TPR / Rubber: TPR / Gummi: TPR

226 Rullini di ritorno flangiati D=60 mm
 Return roller with flange D=60 mm / Rückführrolle mit Seitenscheibe D=60 mm



Delivery: **Easy** **Standard**



Part	Article-Nr.	L	ØA
226	22651	43	16
226	22652	43	18
226	22653	43	20
226	22601	85,5	16
226	22602	85,5	18
226	22603	85,5	20
226	22611	87,5	16
226	22612	87,5	18
226	22613	87,5	20
226	22664	119	12
226	22661	119	16
226	22662	119	18
226	22663	119	20

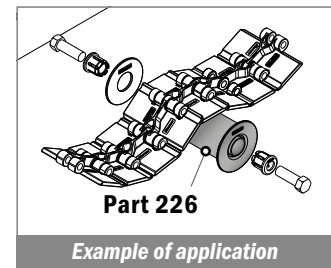
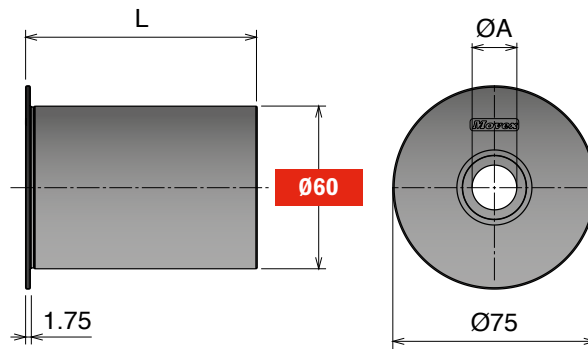

227 Rullini di ritorno flangiati gommati D=67 mm
 Return roller with flange and rubber D=67 mm / Rückführrolle gummiert mit Seitenscheibe D=67 mm



Delivery: **Easy** **Standard**



Part	Article-Nr.	L	ØA
227	22751	43	16
227	22752	43	18
227	22753	43	20
227	22701	85,5	16
227	22702	85,5	18
227	22703	85,5	20
227	22711	87,5	16
227	22712	87,5	18
227	22713	87,5	20
227	22764	119	12
227	22761	119	16
227	22762	119	18
227	22763	119	20

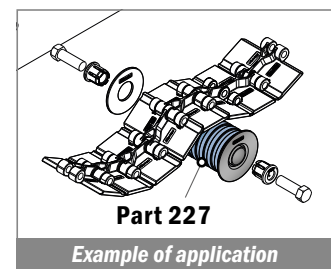
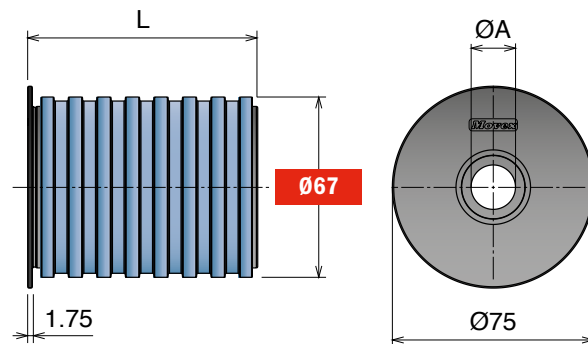

208 Rullini di ritorno flangiati D=42.5 mm Return roller with flange D=42.5 mm / Rückführrolle mit Seitenscheibe D=42.5 mm

Delivery: **Easy** **Standard**

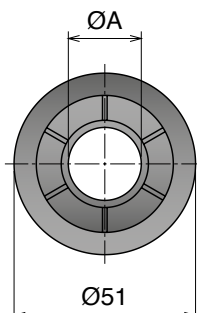
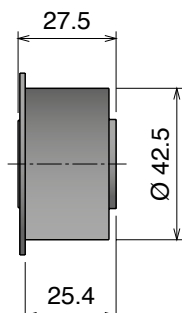

Part	Article-Nr.	ØA
208	20801	16
208	20802	18
208	20803	20

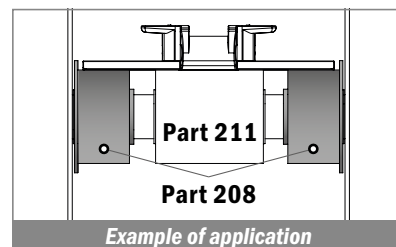

209 Rullini di ritorno flangiati D=43 mm Return roller with flange D=43 mm / Rückführrolle mit Seitenscheibe D=43 mm

Delivery: **Easy** **Standard**

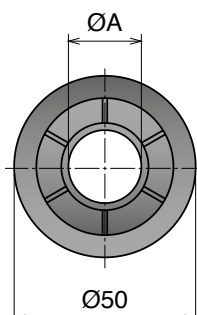
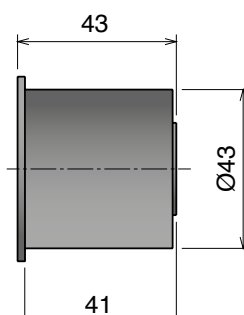

Part	Article-Nr.	ØA
209	20901	16
209	20902	18
209	20903	20

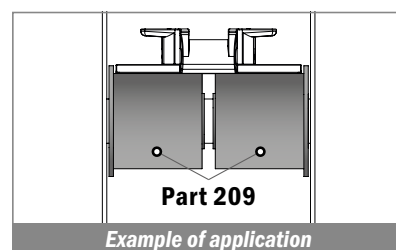

210 Rullini doppio di ritorno Double return roller / Doppel- Rücklaufrolle

Delivery: **Easy** **Standard**

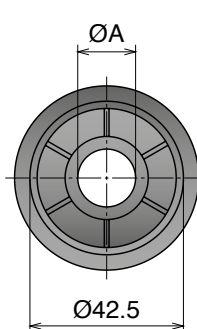
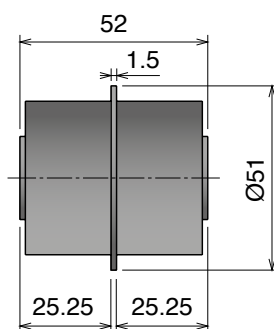

Part	Article-Nr.	ØA
210	21001	16
210	21002	18
210	21003	20

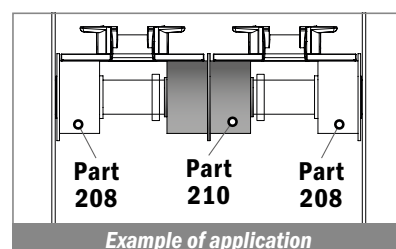

211 Rullini di ritorno D=42.5 mm Return roller D=42.5 mm / Rückführrolle D=42.5 mm

Delivery: **Easy** **Standard**

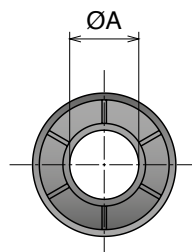
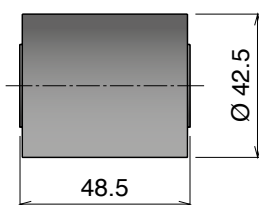

Part	Article-Nr.	ØA
211	21101	16
211	21102	18
211	21103	20

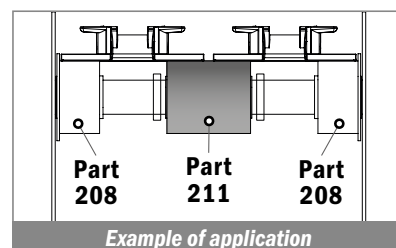

Materiale / Material / Materialien:

Part. 232: Polietilene (PE) / Polyethylene (PE) / Polyäthylen (PE)
 Part. 236/237: Poliammide/Polyamide/Polyamid
 +Gomma NBR/ NBR Rubber/ NBR Gummi

232 Rullini di ritorno flangiati Ø68 Return roller with flange Ø68 / Rückführrolle mit Seitenscheibe Ø68

Delivery: **Easy** Standard

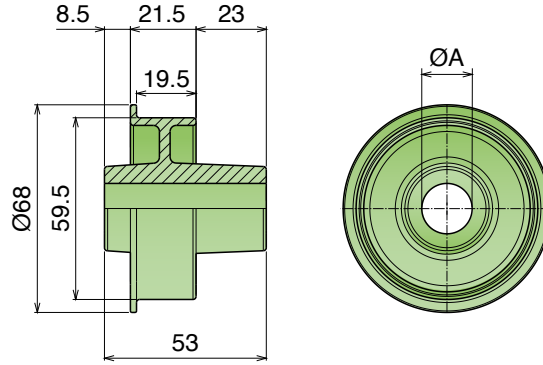

Part	Article-Nr.	ØA
232	23201	15
232	23202	16
232	23203	18
232	23204	20

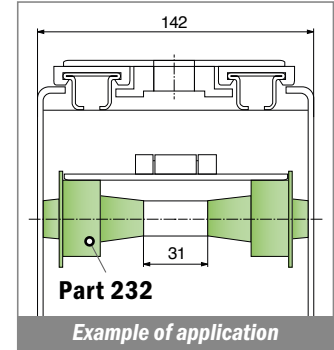

236 Rullini di ritorno con scanalatura Return roller with groove / Rückführrolle mit Nut

Delivery: **Easy** Standard

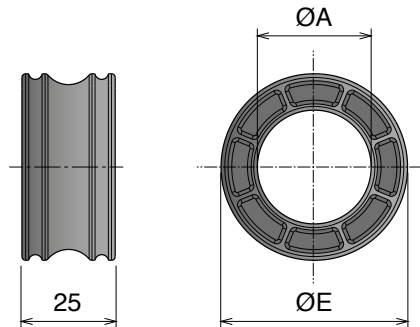

Part	Article-Nr.	ØE	ØA
236	23652	50	30
236	23656	70	30

Used as a return roller or tensioning roller for all the modular belts, especially for the 553 FLEXTOP.

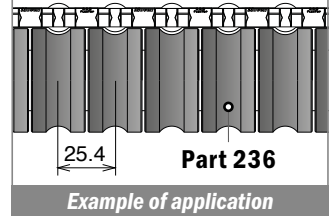

237 Rullini di ritorno con scanalatura e O-ring Return roller with groove and O-ring / Rückführrolle mit Nut und O-ring

Delivery: **Easy** Standard

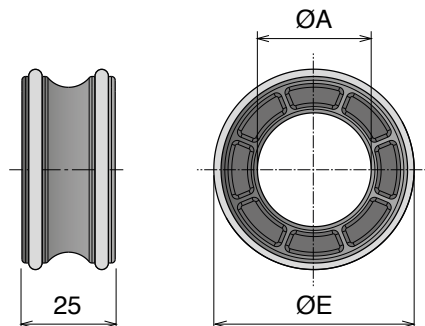

Part	Article-Nr.	ØE	ØA
237	23752	53	30
237	23756	73	30

Used as a return roller or tensioning roller for all the modular belts, especially for the 553 FLEXTOP.

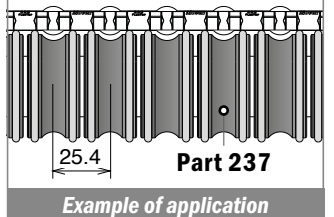

Heavy duty design

Heavy duty design

207 Flangia Flange / Seitenscheibe

Delivery: **Easy** **Standard**

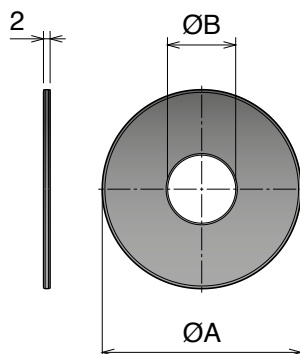

Part	Article-Nr.	ØA	ØB
207	20719	50	12
207	20712	50	16
207	20713	50	18
207	20714	50	20
207	20720	60	12
207	20701	60	16
207	20702	60	18
207	20703	60	20
207	20721	70	12
207	20704	70	16
207	20705	70	18
207	20706	70	20
207	20722	80	12
207	20707	80	16
207	20708	80	18
207	20709	80	20

233 Flangia Flange / Seitenscheib

Delivery: **Easy** **Standard**

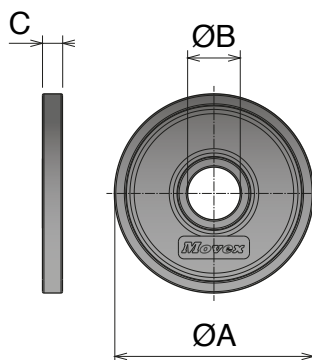

Part	Article-Nr.	ØA	ØB	C
233	23303	25,5	20	7,25
233	23304	60	20	7,25
233	23305	70	16	7
233	23307	70	20	7
233	23302	90	20	5

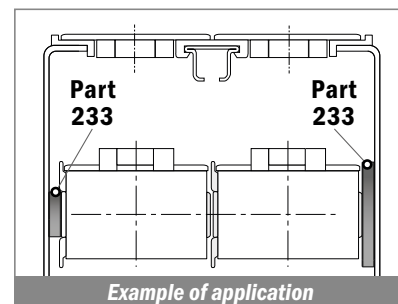

213 Pattino oscillante innesto rapido Snap-on sliding shoe / Rücklaufschuh, aufsteckbar

Delivery: **Easy** **Standard**

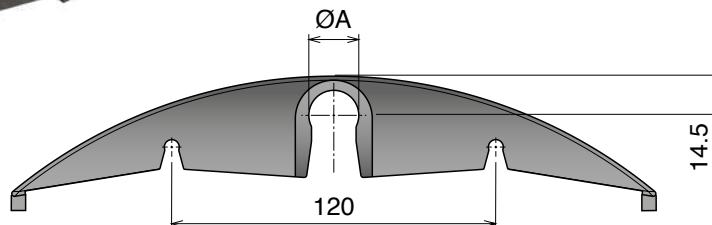

Part	Article-Nr.	ØA
213	21301	16
213	21302	18
213	21303	20

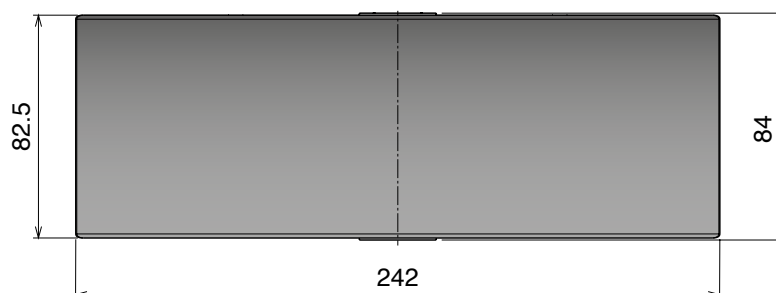
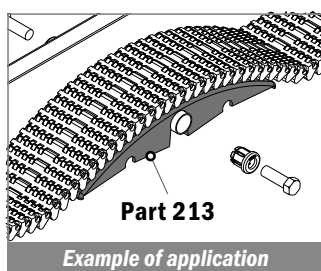

Materiale / Material / Materialien:

Morsetti: Poliammide/Clamps: Polyamide/Klemme: Polyamid

Viti: Acciaio inox/Screws: Stainless steel/Schraube: Edelstahl

Dadi: Ottone nichelato/Nuts: Nickel plated brass/Mutter: Messing vernickelt

221-215-217

Componenti di ritorno / Return components / Rückführelemente

221 Collare di riferimento con chiave Split collar with keyway / geteilter Stelling mit Nut

Delivery: **Easy** **Standard** Max recommended tightening torque: 3 N mt

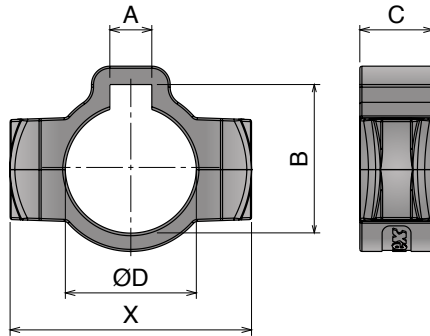

Part	Article-Nr.	A	B	C	ØD	X
221	22101	8	28,3	14	25	46
221	22102	8	33,3	16	30	51
221	22103	10	38,3	16	35	57
221	22104	12	43,3	18	40	64
221	22101Y	6,85	28,3	14	1"	46
221	22102Y	6,85	34,7	16	1,25"	52
221	22104Y	10,025	42,4	18	1,5"	64

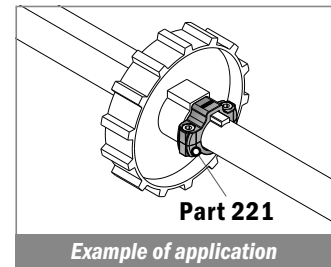

215 Collare di riferimento Split collar / geteilter Stelling

Delivery: **Easy** **Standard** Max recommended tightening torque: 3 N mt

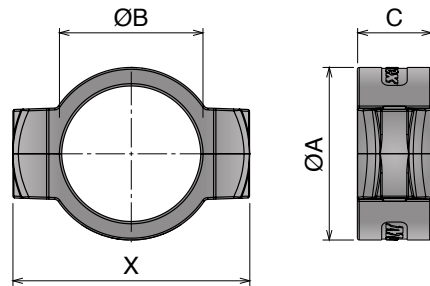

Part	Article-Nr.	ØA	ØB	C	X
215	21501	20	12	12	29,5
215	21502	22	14	12	31,5
215	21509	24	16	12	37
215	21503	26	18	14	42
215	21504	28	20	14	42
215	21505	32	25	14	46
215	21506	38	30	16	51
215	21507	43	35	16	57
215	21508	48	40	18	64
215	21501Y	20	0,5"	12	29,5
215	21503Y	26	0,75"	14	42
215	21505Y	32	1"	14	46
215	21506Y	38	1,25"	16	52
215	21508Y	48	1,5"	18	64

217 Collare di riferimento Split collar / geteilter Stelling

Delivery: **Easy** **Standard** Max recommended tightening torque: 3 N mt

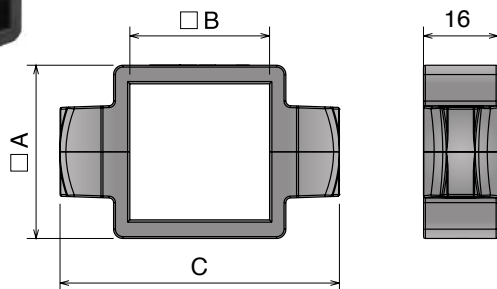

RANGE EXTENSION

Part	Article-Nr.	□A	□B	C
217	21701	33	25	55
217	21702	37	30	60
217	21703	47	40	70
217	21704	59	50	81
217	21705	69	60	92
217	21701Y	1.30	1.00	2.16
217	21702Y	1.57	1 ¼	2.36
217	21703Y	1.85	1 ½	2.75
217	21704Y	2.36	2.00	3.19
217	21705Y	2.87	2 ½	3.62

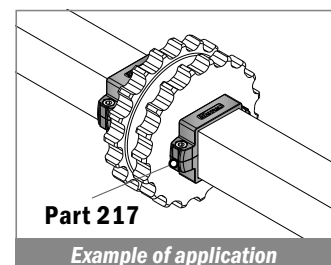

NEW 218 Collare di riferimento in acciaio Stainless steel split collar / Geteilter Stelling, Edelstahl

Stainless Steel | AISI 304

Delivery: **Easy** Standard

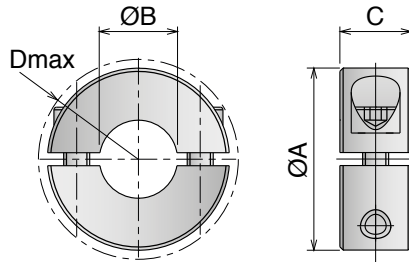

Part	Article-Nr.	ØA	ØB	C	Dmax
218	21801	18	8	9	22,4
218	21802	24	10	9	26
218	21803	28	12	11	31,8
218	21804	34	16	13	39,4
218	21805	36	18	13	41,1
218	21806	40	20	15	46,4
218	21807	45	25	15	50,8
218	21808	54	30	15	58,6
218	21809	58	35	15	62
218	21810	60	40	15	65
218	21801Y	11/16	5/16	5/16	0.88
218	21802Y	7/8	3/8	11/32	1.02
218	21803Y	15/16	7/16	3/8	1.25
218	21804Y	1-1/8	1/2	13/32	1.25
218	21805Y	1-5/16	5/8	7/16	1.55
218	21806Y	1-1/2	3/4	1/2	1.83
218	21807Y	1-3/4	1	1/2	2.00
218	21808Y	2-1/16	1-1/4	1/2	2.31
218	21809Y	2-1/4	1-7/16	9/16	2.44
218	21810Y	2-3/8	1-1/2	9/16	2.56

230 Piastrina Spacer / Führungsscheiben

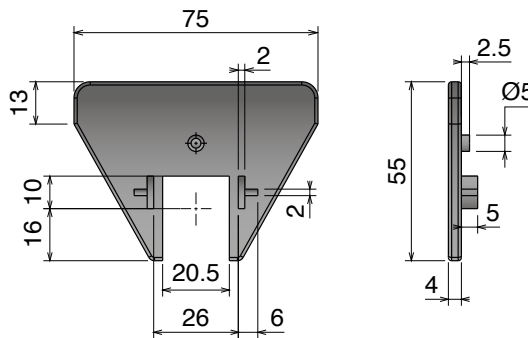

Part	Article-Nr.
230	23001

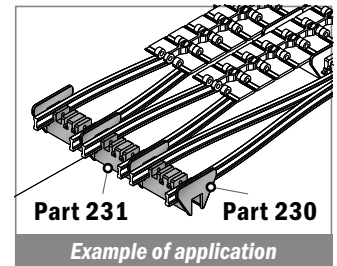

231 Distanziale per serpentina Spacer for serpentine / Montageblock

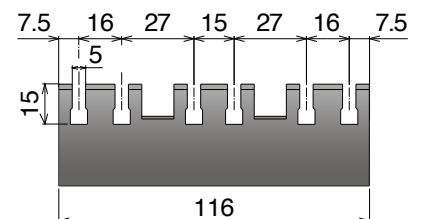
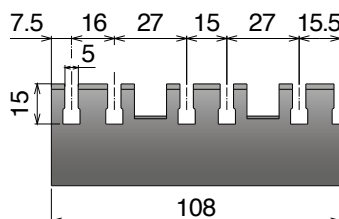
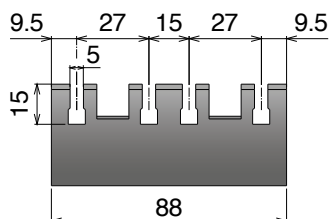
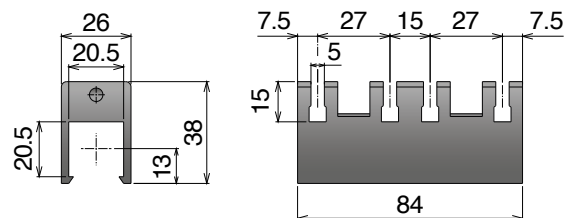

Part	Article-Nr.	W
231	23101	84
231	23102	88
231	23103	108
231	23104	116



Movex
OFFICIAL UK PARTNER

Oadby Conveyors

Oadby Conveyors
68 Scudamore Road
Braunstone Frith Ind. Est.
Leicester
LE3 1UA

0116 232 4848
convteam@oadbyplastics.co.uk

Head Office

Oadby Plastics Ltd
68 Scudamore Road
Braunstone Frith Ind. Est.
Leicester
LE3 1UA

0116 232 1010
sales@oadbyplastics.co.uk

For further information and specification details please visit our comprehensive website. Due to a policy of continual product development, Oadby Conveyors reserves the right to alter any of the specifications given in the publication without prior notice. The specification must be checked with Oadby Conveyors prior to manufacture. For this reason no responsibility or liability for accuracy is accepted by Oadby Conveyors.

Company registration No. 03542957 | www.oadbyconveyors.co.uk



Certificate Number 8147
ISO 9001, ISO 14001